

BAG & BOX TIPPING

QUALITY HANDLING EQUIPMENT



Twin Box Tippers with forward conveyors



150° Box Tipper with forward conveyor



Heavy duty 160° Bag & Box Tipper

Our range of bag & box tippers is comprehensive & offers gentle, efficient handling of crop

Designed to meet your specific requirements and manufactured with the latest technology and safety features, Tong's bag and box tippers offer robust and reliable tipping, with gentle handling in mind.

Tong's Heavy Duty 160° Control Flow Box Tipper is one of the widest tipping box tippers on the market. The tipper features the latest ram tipping mechanism design with enhanced strength, resulting in less strain on linkages for an even more robust and low maintenance machine. The fully automated tipper handles boxes up to 2 tonnes, or can be custom built to effectively tip and empty 1.25 ton bags.

HEAVY DUTY 160° BOX TIPPER SPECIFICATION DATA

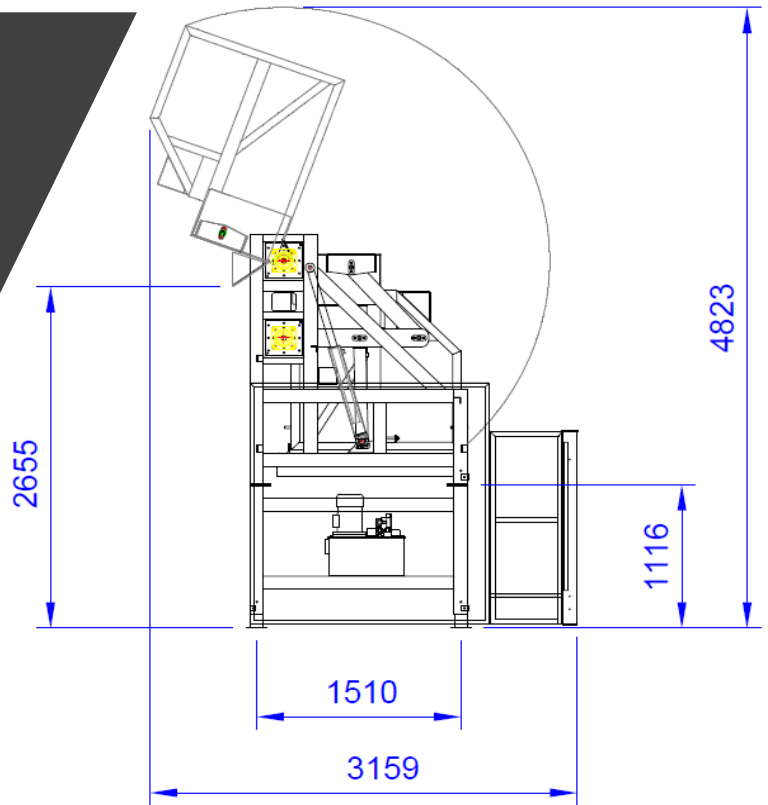

Heavy Duty 160° Control Flow Box Tipper:

Manufactured with the latest ram tipping mechanism for robust and efficient tipping

Optional Extras include:

- Cross Conveyor
- Forward Conveyor (as pictured below)
- Auto-speed change
- Side-eject mechanism
- Hydraulic clamp lid
- Hydraulic flow door
- Single machine with twin hydraulic rams
- 160° heavy duty tip mechanism
- Automatic via micro-processor and sensors
- Manual override in control panel
- Box movement siren
- Box empty beacon
- One set cradle inserts
- Side safety guards
- Light guards (not fitted when machine raised above 1.8m)
- Minimum cycle time 28 seconds
- Manually adjustable flow door



T/ +44 (0)1790 752771
F/ +44 (0)1790 753611
E/ sales@tongengineering.com

Tong Engineering Ltd, Ashby Road, Spilsby, Lincolnshire, PE23 5DW

WWW.TONGENGINEERING.COM